

INTERACTIONS BETWEEN COLUMN INCLUSION AND SURROUNDING SOIL IN COMPOSITE GROUND

Gung-Xin Li¹, Wen-Feng Huang² and Keizo Ugai³

ABSTRACT: The interaction between column inclusions and surrounding soil in composite ground is an important factor that influences the bearing capacity and settlement behaviors of the composite ground. In this paper, interaction between column inclusion (granular column or compressible pile) and surrounding soil are systematically studied by means of laboratory and field tests and theoretical analyses. This paper presents that interaction behaviors of composite ground with granular columns and that with compressible piles are quite different: in the former case, the interaction is mainly laterally, while in the later case, the interaction is mainly vertically. This study shows that for the composite ground with granular columns, it is necessary to insure enough lateral restraint for the column, especially at the upper part of the column; for the composite ground with compressible piles, a sand mat with certain thickness on the top of the pile is important to reduce the stress concentration on the column inclusion and useful to make compatible working between the column inclusion and foundation soil.

INTRODUCTION

In a composite ground as shown in Figs. 1 and 2, the stress-strain relationship of the column inclusions such as compacted gravel, stone, sand or cemented soil is much different from that of the foundation soil, such as soft clay, loose sand, silt etc. The difference results in the different interaction between column inclusion and surrounding soil in composite ground. Commonly the interaction is complicated and has great influence on the bearing capacity and settlement behavior of the composite ground. Generally, there are two kinds of interactions between the column inclusion and surrounding soil: mechanical one and physical-chemical one. In this paper, only the former one is discussed.

The mechanical interaction has been usually considered as “1+1=2”, i.e. the modulus and bearing capacity of composite ground have been considered to be the sum of that of column inclusion and surrounding soil weighted by replacement ratio as follows:

$$f_c = (1-m)f_s + m \cdot f_p \quad (1)$$

$$E_c = (1-m)E_s + m \cdot E_p \quad (2)$$

where f_c, f_s, f_p are separately the bearing capacities of composite ground, surrounding soil and pile; E_c, E_s, E_p are the modulus of composite ground, surrounding soil and column inclusion respectively, m is the replacement ratio of the composite ground. However, in fact, the actual values are not so easy to determine. It also depends on the column inclusion type, construction condition, etc. Sometimes it behaves as “1+1=2” or “1+1>2”; sometimes

1 Professor, Department of Hydraulic Engineering, Tsinghua University, Beijing 100084, CHINA.

2 Postdoctoral Fellow, Department of Civil Engineering, Gunma University, Gunma 376-8515, JAPAN.

3 Professor, Department of Civil Engineering, Gunma University, Gunma 376-8515, JAPAN.

Note: Discussion on this paper is open until December 25, 2000.

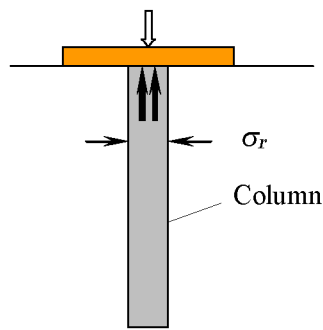

Fig. 1 Typical element of composite ground

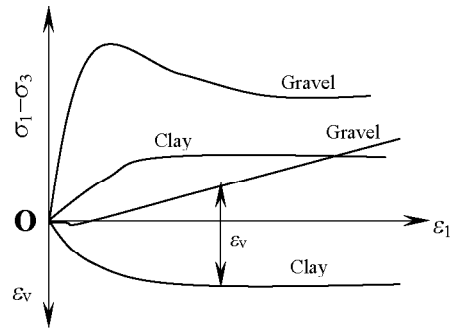

Fig. 2 Stress-strain curves of gravel and clay

behaves as “1+1<2”, or even “1+1<1”, if unreasonable design and construction are adopted.

Stone column is one of the popular types of foundation treatment all over the world. It has been studied by many researchers and been understood to some extent. According to model tests, Hughes and Withers (1974) found that the settlement and failure of stone column mainly result from bulging of upper part of the column. Based on model tests on composite specimens with cemented stone column in a modified triaxial apparatus, Juran and Riccobono (1991) studied the cementation effect on the performance of the granular column and the group effect on the settlement response of the reinforced soil.

Based on the characteristics of stone column-soil interaction, some calculation methods of bearing capacity and settlement of composite ground with stone column have been proposed, and also some engineering measures have been suggested to improve the behavior of the composite ground. Balaam and Poulos (1983) presented a FEM method to calculate the settlement of the composite ground of stone column, in which a section of single column with effective foundation soil was considered as a unit cell. By using pressuremeter test results, Hughes and Withers (1975) presented a settlement calculation method in which the volume of stone column is supposed to be constant and the settlement of the column comes from its distension. Cai (1992) suggested that the settlement of single column could be calculated from the pressuremeter test results of foundation soil and triaxial test results of stone specimen. By analyzing of the relationship between axial strain ε_1 and stress ratio σ_1/σ_3 , also the relationship between ε_1 and volumetric strain ε_v , Poorooshab and Meyerhof (1997) presented an expression of load-settlement relationship of composite ground with stone column.

The interaction between compressible or rigid piles and surrounding soil is considered to be axially. The friction on the interface of pile and soil plays an important role in load transferring. Seed and Reese (1957) presented that the settlement of a single pile could be calculated by using load transferring function (the friction-displacement relationship between pile and soil). Poulos and Davis (1968, 1980) divided a pile into some elements, the friction on each element was assumed to be uniform, and analyzed the settlement behavior of single pile by using Mindlin's equations (Mindlin 1936). Randolph and Wroth (1978) presented a load-transferring model in which the foundation soil was supposed to be a series of concentric cylinders and they interact between each other by shear stress. Yan et al. (1995) presented that the silty mat between the loading plate and the pile top has important effect on the settlement and bearing behavior of the composite ground with compressible pile or rigid pile. The sand mat reduces the stress concentration of the pile so that it improves the compatibility between pile and surrounding soil.

In this paper, the lateral interaction in composite ground with gravel column and vertical interaction in composite ground with compressible pile are systematically analyzed through laboratory model tests, field tests, theoretical calculation. Some of the countermeasures for

engineering practice are suggested to improve the behavior of composite ground.

COMPARISON OF STRESS-STRAIN RELATIONSHIP BETWEEN THREE KINDS OF MATERIALS

The stress-strain relationships of clay, cemented clay and granular material are different. The stress-strain characteristics determine the interaction behavior of the composite. The comparisons of the stress-strain relationships are as follows:

Gravel and Clay

Figure 2 shows the stress-strain curves of gravel and clay in conventional triaxial compression tests. From this figure, it can be drawn that:

- The modulus and strength of gravel are much higher than that of clay under the same confining pressure σ_3 .
- The volumetric strain of gravel is negative, i.e. its volume deformation is dilatation while the volumetric strain of clay is positive. The different volumetric strain ($\Delta\varepsilon_v$) of the two kinds of materials is significant.
- The difference of volumetric strain $\Delta\varepsilon_v$ may cause a strong lateral interaction between the column and the surrounding soil by increasing the radial stress σ_r .

Clay and Cemented Soil

Figure 3 depicts the test results of clay and cemented soil. From this figure following conclusions can be obtained:

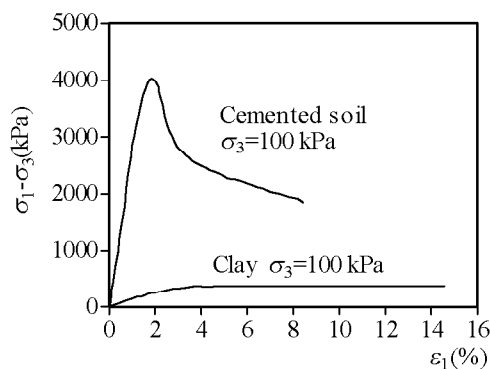

Fig. 3 Stress-strain curves of cemented soil and clay

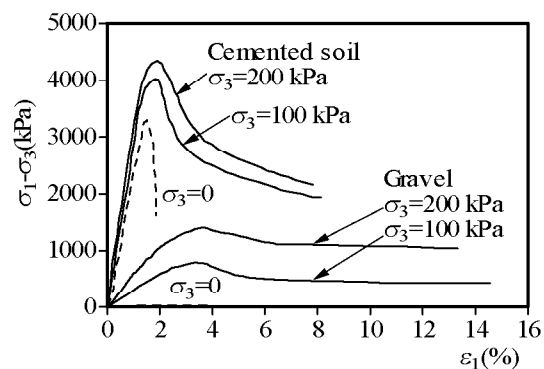

Fig. 4 Stress-strain curves of gravel and cemented soil under different confining pressures

- The modulus and strength of cemented soil are much higher than that of clay under the same confining pressure σ_3 .
- The failure strain of cemented clay is very small in comparison with that of clay. Therefore, for a certain point of axial strain, for example, point of axial strain being 3%, the failure of the pile may firstly occur because of the stress concentration on it. For this kind of composite ground, the compatibility of the axial strains of the two materials may be very important.

Gravel and Cemented Soil

From Fig.4, it can be seen that:

a) Without confining pressure, unconfined shear strength of cemented soil is much higher than that of gravel.

b) For gravel, its modulus and strength strongly depend on the confining pressure, however, the confining pressure only has a little effect on modulus and strength of cemented soil.

From these comparisons, it can be drawn that in composite ground with gravel columns, the difference of volumetric strain between columns and foundation soil may cause a strong lateral interaction between two materials and the confinement on the column is very important, while in composite ground with compressible piles (for example, cemented soil piles), the compatibility of the axial strains of the two materials is very important.

LATERAL INTERACTION BETWEEN GRAVEL COLUMN AND SURROUNDING SOIL

Model Test

The apparatus (see Fig.5a) is modified from triaxial apparatus. In order to simulate a typical element of composite ground, the sample consists of a model gravel column in the center and clay surrounded. The soil is unsaturated Baihepu Clay with plasticity index $I_p=10.1$, dry density $\gamma_d = 15.2 \text{ kN/m}^3$ and natural water content $w=16\%$. Parameters of the gravel used in the tests were: mean diameter $d_{50}=3.66 \text{ mm}$, coefficient of uniformity $C_u=1.95$, dry density $\gamma_d=16.7 \text{ kN/m}^3$ and relative density $D_r=75\%$ (Huang, 1999).

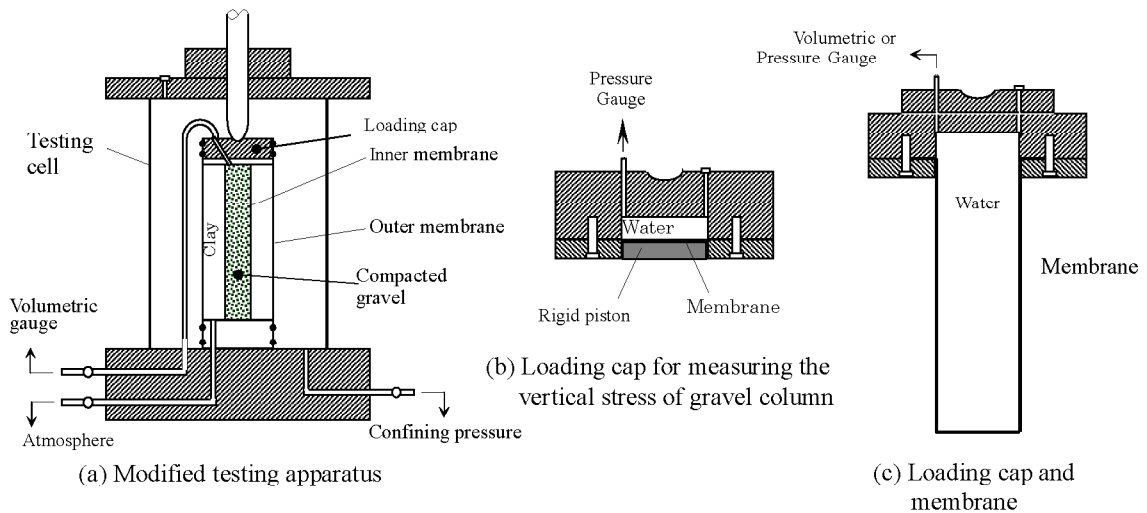

Fig. 5 Modified testing apparatus, loading cap and membrane

In these tests, the vertical stress σ_p on the gravel column, the radial stress σ_r on the inner surface of gravel column and the surrounding clay, the volumetric strain ε_v of the gravel column can be measured by using the loading cap and membrane as shown in Figs.5b and 5c.

Test Results

In triaxial tests of composite samples, the confining pressure in the testing cell was defined

as σ_{30} . The tests showed that the radial contact stress σ_r on interface is higher than σ_{30} , which results from the dilatation of the gravel when loaded. Figure 6 shows the measured curves of radial contact stress σ_r (real confining pressure and minimum principal stress on the gravel column) varying with the axial strain ε_a under the three cell pressures. Generally, σ_r is $(1.2\sim 1.5)\sigma_{30}$.

Unlike the gravel column, the minimum principal stress σ_3 of the surrounding clay is σ_θ , where σ_θ is the circumferential stress on the interface. Because of the dilatation of granular material, at the point near the interface in surrounding soil, $\sigma_\theta < \sigma_{30}$. Figure 7 shows that in comparison with the results of conventional triaxial tests of clay and gravel under the same confining pressure σ_{30} , the strength of gravel is higher and strength of clay is lower in the composite samples.

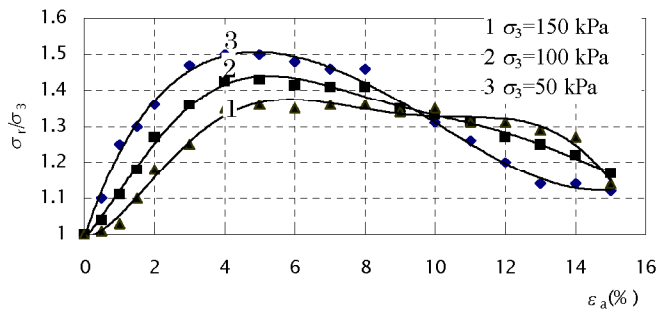

Fig.6 Radial contacting stress on the interface of gravel column and surrounding soil

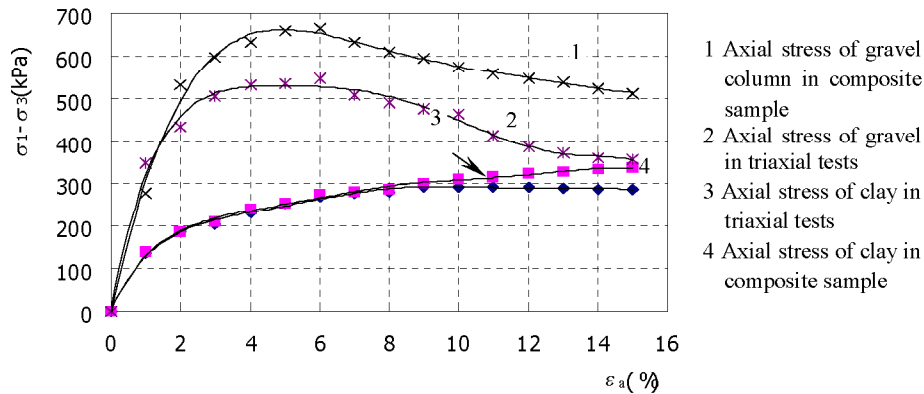

Fig. 7 Axial stress-strain curves of gravel and clay in different test ($\sigma_{30}=100$ kPa)

Calculation Results

A numerical analysis has been carried out by using an elasto-plastic model (Yang, 1998), which can describe the dilatant behaviors of granular materials. Figure 8 shows the calculated minimum principal stress of the gravel column and the surrounding clay on the inner interface. The predicted minimum principal stress σ_3 of gravel column from numerical analysis shown in Fig. 8a is significantly larger than the confining pressure σ_{30} and the $\sigma_3\sim\varepsilon_a$ curve is quite close to the tested curve shown in Fig.6. Meanwhile, the predicted minimum principal stress σ_3 of clay on the inner interface shown in Fig.8b is much less than the confining pressure σ_{30} . From Fig.8, it can be seen that the strengthening of the gravel column and the weakening of

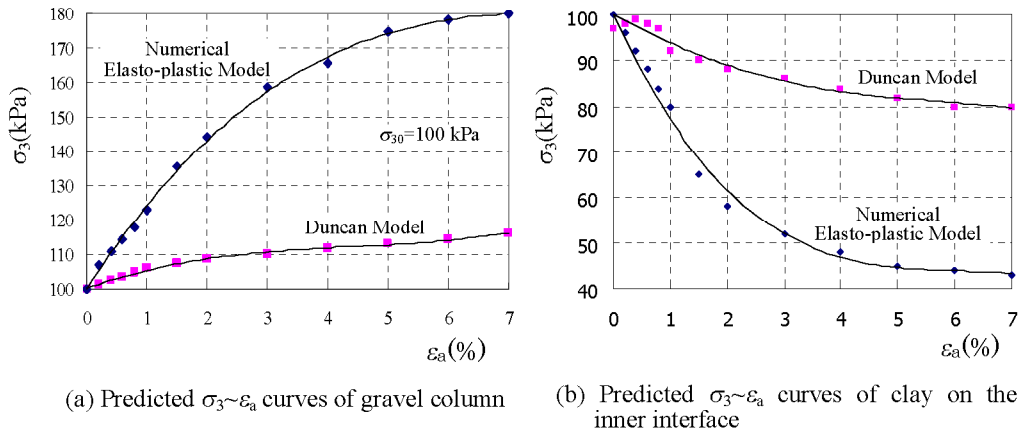

Fig. 8 Predicted $\sigma_3 \sim \epsilon_a$ curves of gravel column and clay in composite sample (after Yang 1998)

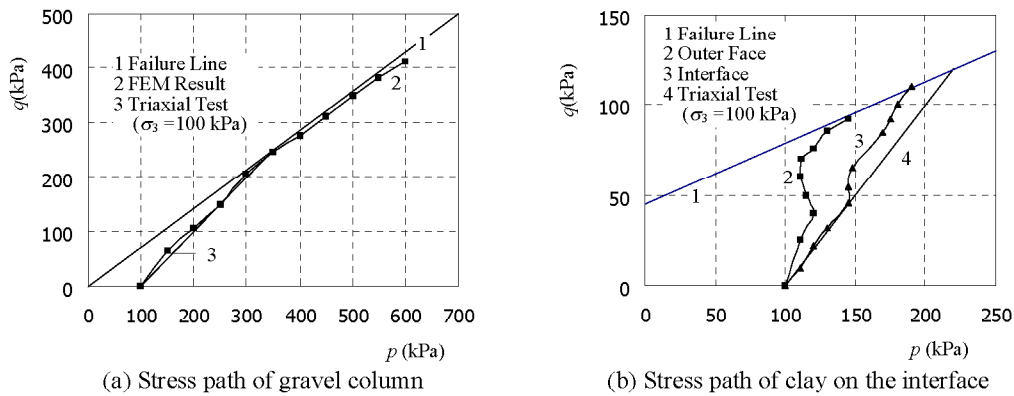

Fig. 9 Stress path of gravel column and clay (after Tian, 1997)

the surrounding soil happen due to vertical loading, and the dilatancy of gravel columns causes the strong lateral interaction between columns and soil in this kind of composite ground.

The computed stress paths in Fig. 9 (Tian, 1997) show that due to the dilatancy of gravel, the strength of gravel increases considerably while that of the surrounding clay decreases significantly in comparison with the results of conventional triaxial tests.

Suggestions

In order to increase the bearing capacity and decrease the settlement of composite ground with granular columns, enough restraint of the column, especially at its upper part is necessary. The following suggestions are made for design of this kind of composite grounds:

- a) To avoid using granular column in soft clay if $c_u < 20$ kPa.
- b) To use geosynthetic reinforcement in granular columns, for example, use geotextile bags which can restrict the gravel column effectively. Other type such as reinforced gravel column with geogrids may be also useful. Figure 10 shows the settlement behaviors of the composite ground with gravel column with different layers of geogrids in it. The symbol N in Fig.10 is the number of geogrid layers, and the layer spacing is about $0.5D_0$ (D_0 is the diameter of the column).
- c) To install some short gravel columns around a long pile in order to increase the

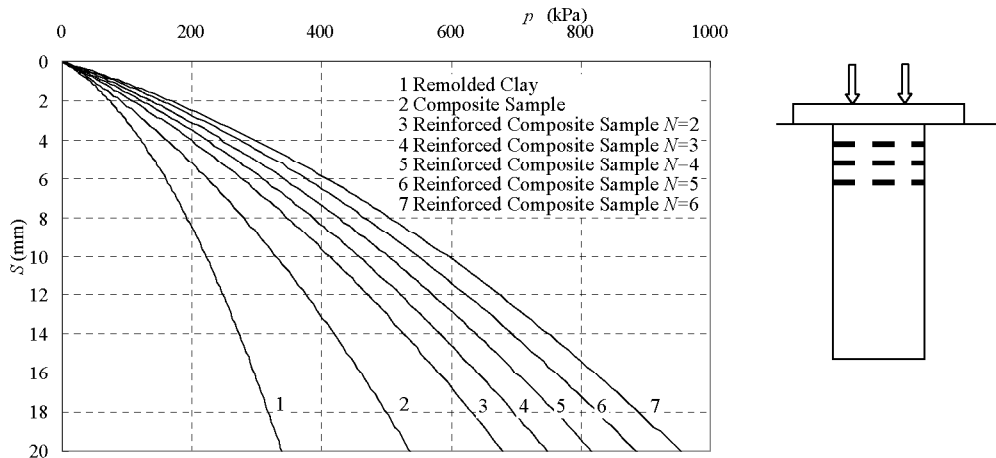

Fig. 10 p - S curves of composite grounds of gravel column with different layer geogrids (after Cai and Li, 1992)

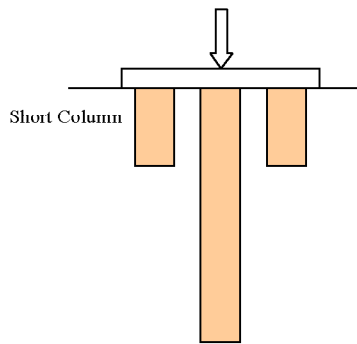

Fig. 11 Long column with short ones

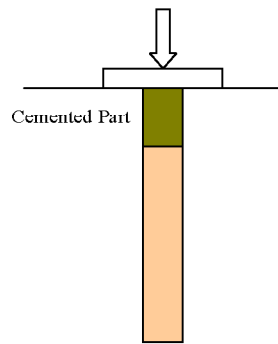

Fig. 12 Gravel column with cemented part

confining pressure (see Fig. 11).

d) To install a cemented part in the upper part of each column in order to overcome the small confining pressure near the ground surface (see Fig. 12).

AXIAL INTERACTION BETWEEN COMPRESSIBLE PILE AND SOIL

Laboratory Model Test

The triaxial tests of composite sample with lime-clay (a kind of cemented soil) pile were performed (Tian, 1997) in the apparatus as shown in Fig.5a and using the load cap as shown in Fig.5b. In comparison with the gravel column model tests, there is a significant difference. In gravel tests, the failure of the column inclusion in composite sample occurs accompanied by dramatic volumetric strain and axial strain, while in the lime-clay tests, the failure occurs when fractures appears in the column or surrounding clay. The axial strain of the cemented soil at failure point is much less than that of the gravel column. As discussed aforementioned, the failure of column may first occur in this kind of composite ground. Therefore, for soil cement column, some countermeasures must be done to prevent it from fracture. In

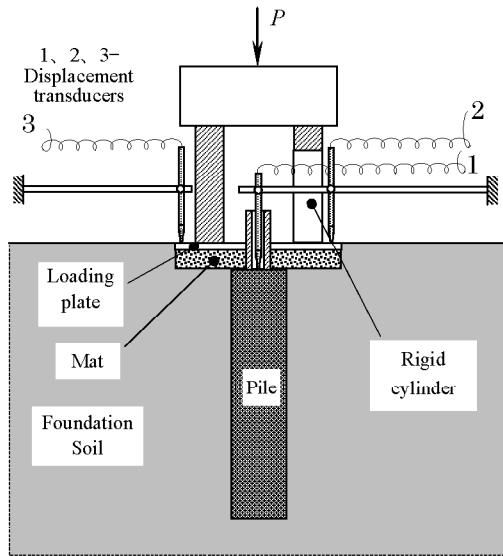

Fig. 13 Loading test on composite unit

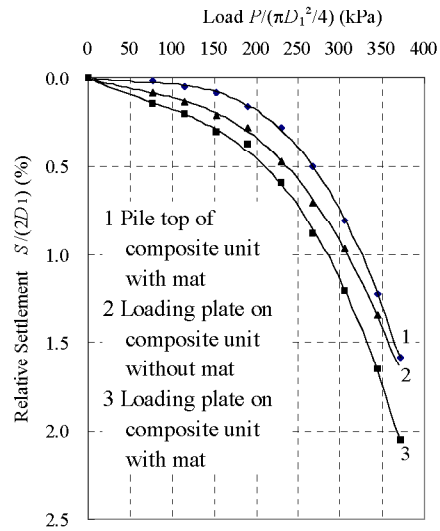

Fig. 14 Load-settlement curves

engineering practice, installing a sand mat (see Fig.13) can reduce quite a lot the axial strain of column and make column and soil work compatibly.

Field Tests

In field tests, the soil at field test site was backfill of homogeneous silty clay. The soil cement pile is made up of compacted mixture with silty clay and cement. The length L is 3.4 m, the diameter D_0 is 0.35 m and the diameter of the loading plate D_1 is 0.80 m. Figure13 is the sketch of the test. In the tests, the displacements of loading plate and the pile top were measured. Figure14 shows comparison of load-settlement curves of composite ground with and without silty mat. The settlement of pile top is also shown in this figure. It can be seen that the settlement of pile top is less than that of the surrounding soil if provided with a silty mat under the loading plate.

From Fig. 14, it can be seen that the settlement behavior of composite ground with compressible piles relies on the mat under the loading plate. Furthermore, it can be drawn that the behavior relies on the axial interaction between the column inclusion and surrounding soil because the mat just change the distribution of friction along the interface between the pile and surrounding soil and optimize the axial interaction between them.

Theoretical Analysis of Settlement of Composite Ground with Compressible Piles

If the foundation soil is assumed to be homogeneous, elastic and semi-infinite, according to Mindlin's solution (Mindlin, 1936) the settlement of typical element of composite ground in the field tests can be obtained (Huang, 1999).

The total load P acting on subsoil can be divided into three parts: the load along the shaft P_L , the load at the bottom of the pile P_b and the load on the soil P_s as Eq.(3):

$$\left. \begin{aligned} P &= P_L + P_b + P_s \\ P_L &= \alpha \cdot P = \int_0^L \tau(h) dh \\ P_b &= \beta \cdot P \\ P_s &= \gamma \cdot P \end{aligned} \right\} \quad (3)$$

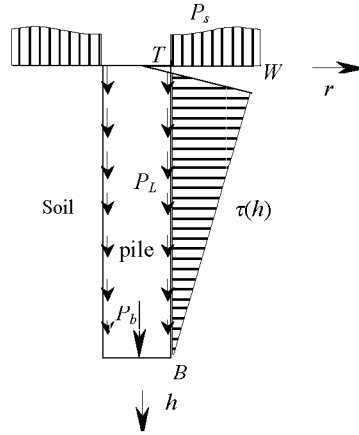

Fig. 15 The load distribution

Thus the relationship of settlement and load can be given by

$$S = \frac{1+\nu_s}{2\pi E_s L} \cdot P \cdot [\alpha \cdot k_{Lt} + \beta \cdot k_{bt} + \gamma \cdot k_{st}] \quad (4)$$

and

$$(\alpha \quad \beta \quad \gamma)^T = \begin{bmatrix} 1 & 1 & 1 \\ k_{Lt} - k_{Lw} & k_{bt} - k_{bw} & k_{st} - k_{sw} \\ k_{Lt} & k_{Lb} & k_{0d} & \frac{1}{3} k_{0p} & k_{bt} & k_{bb} & k_{0d} & k_{0p} & k_{st} & k_{sb} \end{bmatrix}^{-1} \cdot \begin{pmatrix} 1 \\ 0 \\ 0 \end{pmatrix} \quad (5)$$

where \$S\$ is the settlement(m); \$P\$ is the total load (kN); \$\alpha\$, \$\beta\$, and \$\gamma\$ are the load distribution coefficients of pile shaft, pile bottom and surrounding soil, respectively; \$P_L\$, \$P_b\$, and \$P_s\$ are the load along the shaft, at pile bottom and on the soil (see Fig.15, \$\tau(h)\$ is shear stress along the shaft), respectively; \$E_s\$ and \$\nu_s\$ are the Young's modulus and Poisson's ratio of foundation soil; \$L\$ is the length of the pile; \$k_{ij}\$ is the coefficient of settlement, in which the first subscripts \$i=L, b, s\$, indicate the three parts of load: \$P_L, P_b, P_s\$, and the second subscripts \$j=t, w, b\$, indicate the place of settlement caused by the load (see Fig.15); \$k_{0p}, k_{0d}\$ are material coefficient of the pile and sand mat, respectively, and it can be expressed by Eq.6:

$$k_{0p} = \frac{8\lambda^2}{(1+\nu_s)(E_p/E_s)} \quad (6a)$$

$$k_{0d} = \frac{\delta}{L} \cdot \frac{8\lambda^2}{(1+\nu_s)(E_d/E_s)} \quad (6b)$$

where \$\lambda\$ is the relative pile length \$L/D_0\$ and \$\delta\$ is the thickness of the mat.

The coefficients of settlement \$k_{ij}\$ are functions of geometric parameters (pile length \$L\$, pile diameter \$D_0\$, plate diameter \$D_1\$, etc.) of the composite system, and they all can be described

analytically.

Based on the analytical solution, following results can be obtained:

(1) Effective pile length

If the pile is with a certain length, the distribution coefficient of the bottom β will be close to 0, i.e. the end-bearing reaction of the pile can be negligible. In this case, the length of pile is defined as effective pile length L_{eff} . It is related to the modulus ratio of pile to soil E_p/E_s , the modulus ratio of mat to soil E_d/E_s , the replacement ratio m , and the relative thickness of mat δ/L . Table 1 shows the effective pile length under different conditions. Here, λ and λ_{eff} are the relative pile length L/D_0 and L_{eff}/D_0 , respectively, where D_0 and D_1 are the diameter of the pile and the loading plate, respectively. δ is the thickness of mat and E_d , E_s are Young's Modulus of mat and foundation soil.

From Table 1, it can be seen that:

- The higher the modulus ratio of pile to soil, the longer the effective pile length will be.
- The installation of sand mat can reduce the effective length of pile.

(2) Load distribution coefficients α , β , γ

Calculated load distribution coefficients α , β , and γ are shown in Table 2. From Table 2, it can be drawn that:

- The installation of sand mat increases the amount of load on the surface of the surrounding soil.
- The high modulus ratio E_p/E_s leads to large amount of load to be transferred to the pile bottom.

Table 1 The efficient pile length in loading test of composite ground unit:m

E_p/E_s	$\lambda_{eff} (E_d/E_s=2)$					
	$m=0.15$			$m=0.3$		$m=1.0$
	$\delta/D_1=0$	$\delta/D_1=0.1$	$\delta/D_1=0.2$	$\delta/D_1=0$	$\delta/D_1=0.1$	Single Pile
20	18.1	13.7	10.2	14.0	11.3	8.6
40	26.9	17.5	12.2	21.0	15.8	13.7
60	33.8	19.3	13.1	26.6	18.1	17.7
80	39.7	20.4	13.5	31.3	19.5	21.2
100	44.8	21.2	13.8	35.5	20.5	24.4
500	106.7	23.9	14.9	86.3	24.4	63.7
1000	154.3	24.3	15.0	125.8	25.0	95.1

Table 2 The load distribution coefficients α , β , γ

E_p/E_s	$\lambda=10, m=0.15$					
	$\delta/D_1=0$			$\delta/D_1=0.2$		
	α	β	γ	α	β	γ
20	0.212	0.072	0.716	0.229	0.002	0.769
40	0.199	0.129	0.672	0.223	0.025	0.751
60	0.192	0.159	0.649	0.221	0.037	0.743
80	0.187	0.178	0.635	0.219	0.043	0.738
100	0.184	0.190	0.625	0.218	0.048	0.734
500	0.173	0.240	0.587	0.214	0.063	0.722
1000	0.171	0.247	0.582	0.214	0.066	0.720

Table 3 The stress ratio $n = \sigma_p / \sigma_s$

E_p/E_s	$\lambda=10, m=0.15$			$\lambda=10, m=0.3$			$\lambda=5, m=0.15$
	$\delta/D_1=0$	$\delta/D_1=0.1$	$\delta/D_1=0.2$	$\delta/D_1=0$	$\delta/D_1=0.1$	$\delta/D_1=0.2$	$\delta/D_1=0.1$
20	2.25	1.93	1.70	2.44	2.19	1.71*	1.36
40	2.77	2.24	1.88	2.92	2.50	2.19	1.54
60	3.07	2.40	1.97	3.19	2.67	2.29	1.62
80	3.26	2.49	2.02	3.37	2.77	2.35	1.67
100	3.40	2.56	2.05	3.50	2.84	2.39	1.70
500	3.98	2.82	2.18	4.03	3.12	2.54	1.81
1000	4.07	2.86	2.20	4.12	3.16	2.57	1.82

* $\lambda > \lambda_{eff} = 7.76$, let $\lambda = \lambda_{eff}$

(3) Stress ratio

The stress ratio $n = \sigma_p / \sigma_s$ under different conditions are listed in Table 3. From Table 3, it can be obtained that:

a) The stress ratio $n = \sigma_p / \sigma_s$ increases if the modulus ratio E_p/E_s increase. However, when E_p/E_s is greater than a certain value (in this example, the certain value of E_p/E_s is about 100), the stress ratio n increases only a little. It means that it is not effective to improve the stress ratio by increasing the modulus ratio when it is over a certain value.

b) A deformable mat on the top of the pile decreases the stress ratio $n = \sigma_p / \sigma_s$ significantly.

c) The longer the pile is, the larger stress ratio will be.

These results describe the axial compatibility between pile and foundation soil. The axial interaction between pile and surrounding soil balances the load distribution on the pile and the surrounding soil. The mat between the load plate and the pile can reduce the stress concentration on the pile and help the pile and foundation soil work cooperatively.

CONCLUSIONS

In this study, following conclusions can be drawn.

1. The interaction between column inclusion and surrounding soil in composite ground is a most significant factor for the design of column-improved subsoil.
2. The characteristics of the stress-strain relationships of granular material, cemented soil and foundation soil are quite different. Therefore, the interaction in different types of composite grounds turns out to be different.
3. In composite ground with gravel column, the modulus and strength of gravel strongly depend on the confining pressure. In addition, dilatancy of gravel brings lateral interaction between column and surrounding soil. Engineering countermeasures are necessary to insure the lateral restraint on the gravel column.
4. In composite ground with compressible pile, the modulus and strength of pile are usually much higher than that of foundation soil, the most important thing is the compatibility of the axial strains of piles and foundation soil. The axial interaction between pile and surrounding soil can balance the load distribution on the pile and the surrounding soil. A deformable mat with certain thickness on the top of the pile is necessary to reduce the stress concentration on the pile.

REFERENCES

- Balaam, N. P. and Poulos, H. G. (1983). The behavior of foundations supported by clay stabilized by stone columns. Proc. of 8th ECSMFE, 1.
- Cai, F. (1992). The study of granular piles reinforced with geosynthetics, Master Thesis, Tsinghua Univ., Beijing, China. (in Chinese)
- Huang, W. F. (1999). The interaction between column inclusions and surrounding soil in composite ground. Ph.D. Dissertation, Tsinghua Univ., Beijing, China. (in Chinese)
- Hughes, J. M. O. and Withers, N. J. (1974). Reinforcing soft cohesive soils with stone column. *Ground Engineering*. 7(3): 42-49.
- Hughes, J. M. O., Withers, N. J. and Greenwood, D. A. (1975). A field trial of the reinforcing effect of a stone column in soil. *Geotechnique*. 25(7).
- Juran, I. and Riccobono, O. (1991). Reinforced soft soil with artificially cemented compacted-sand column. *Journal of Geotechnical Engineering, ASCE*. 117(7): 1042-1060.
- Mindlin, R. D. (1936). Force at a point in the interior of a semi-infinite solid. *Physics*. 7(5): 195-202.
- Poorooshasb, H. B. and Meyerhof, G. G. (1997). Analysis of behavior of stone columns and lime columns. *Computer and Geotechnics*. 20(1): 47-70.
- Poulos, H. G. and Davis, E.H. (1968). The settlement behavior of single axially-loaded piles and piers. *Geotechnique*. 18: 351-371.
- Poulos, H. G. and Davis, E. H. (1980). *Pile Foundation Analysis and Design*. John Wiley and Sons, Inc., New York.
- Randolph, M. and Wroth, C. P. (1978). Analysis of deformation of vertically loaded piles. *J. Geotech. Engrg. ASCE*. 104(12): 1465-1488.
- Seed, H. B. and Reese, L. C. (1957). The action of soft clay along friction piles. *ASCE. Translation*. 122: 731-763.
- Tian, H. (1997). Experimental study on the soil-pile interaction in composite foundations, Master Thesis, Tsinghua Univ., Beijing, China. (in Chinese).
- Yan, M. L., Wu, C. L. and Yang, J. (1995). Design of composite ground of CFG pile. Proc. China 4th Symposium of Ground Treatment: 368-372. (in Chinese).
- Yang, G. H. (1998). The mathematical theory for constitutive model of soils and its application. Ph.D. Dissertation, Tsinghua Univ., Beijing, China. (in Chinese).